



(19) **United States**

(12) **Patent Application Publication** (10) **Pub. No.: US 2002/0028626 A1**

Lee et al.

(43) **Pub. Date: Mar. 7, 2002**

(54) **METHOD FOR FABRICATING ORGANIC ELECTROLUMINESCENT DISPLAY**

(30) **Foreign Application Priority Data**

Aug. 24, 2000 (KR) 2000-49287

(76) **Inventors: Seong-Taek Lee, Suwon-city (KR); Jang Hyuk Kwon, Suwon-city (KR); Tae Min Kang, Suwon-city (KR); Joon Young Park, Seoul (KR)**

Publication Classification

(51) **Int. Cl.⁷ H01J 9/00**

(52) **U.S. Cl. 445/24**

(57) **ABSTRACT**

In a method for fabricating an organic electroluminescent display, a first electrode layer is formed on a transparent substrate, and a hole transport layer is formed on the first electrode layer. After an organic luminescent layer is formed on the hole transport layer by scanning a donor film disposed on the substrate using a laser beam, the donor film is removed and then a second electrode is formed on the organic luminescent layer. The laser beam dithers while performing the scanning operation to make the energy distribution uniform.

Correspondence Address:
STAAS & HALSEY LLP
700 11TH STREET, NW
SUITE 500
WASHINGTON, DC 20001 (US)

(21) **Appl. No.: 09/935,332**

(22) **Filed: Aug. 23, 2001**

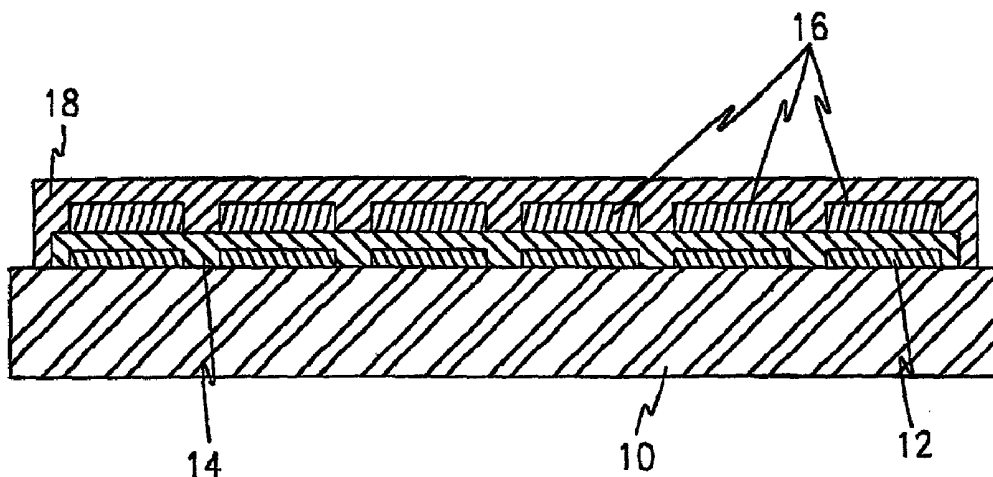

FIG.1
(Conventional Art)

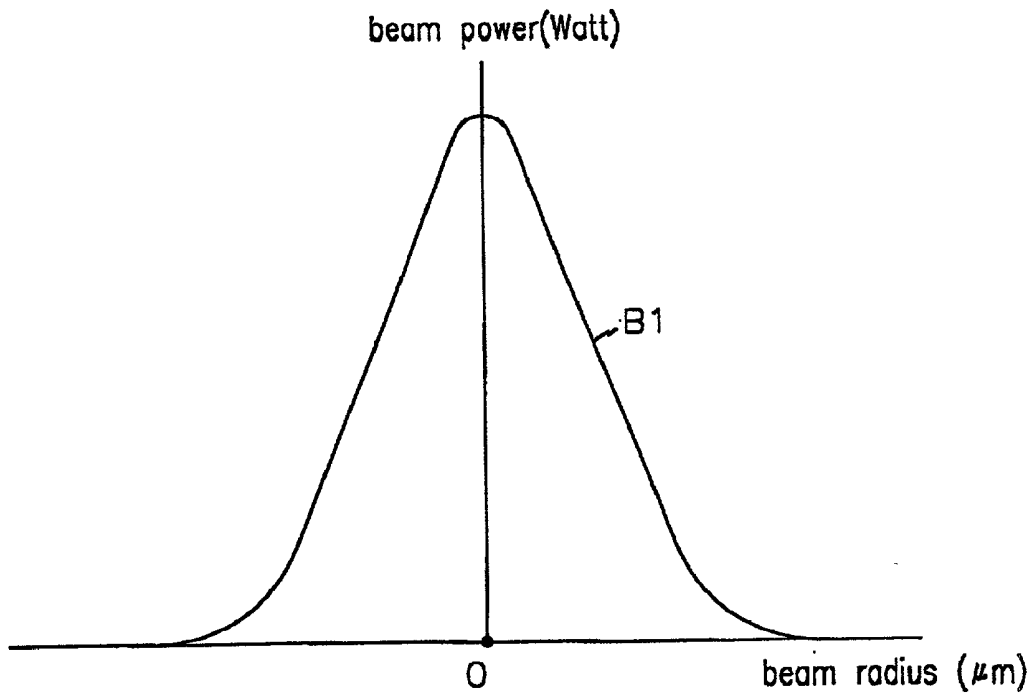

FIG.2
(Conventional Art)

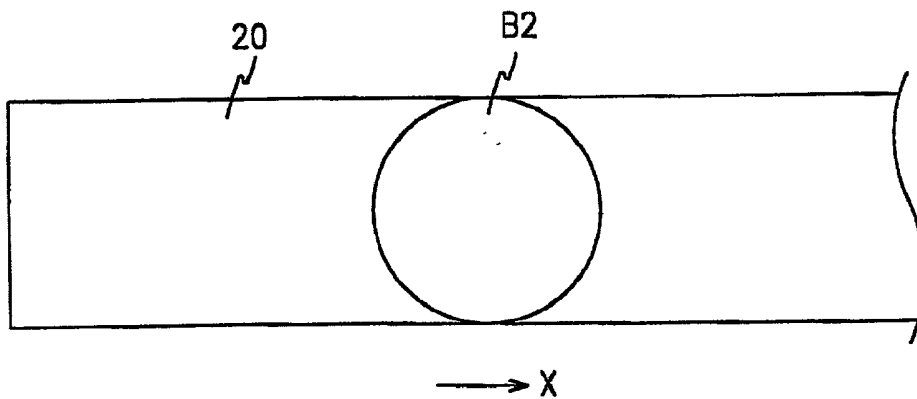

FIG. 3

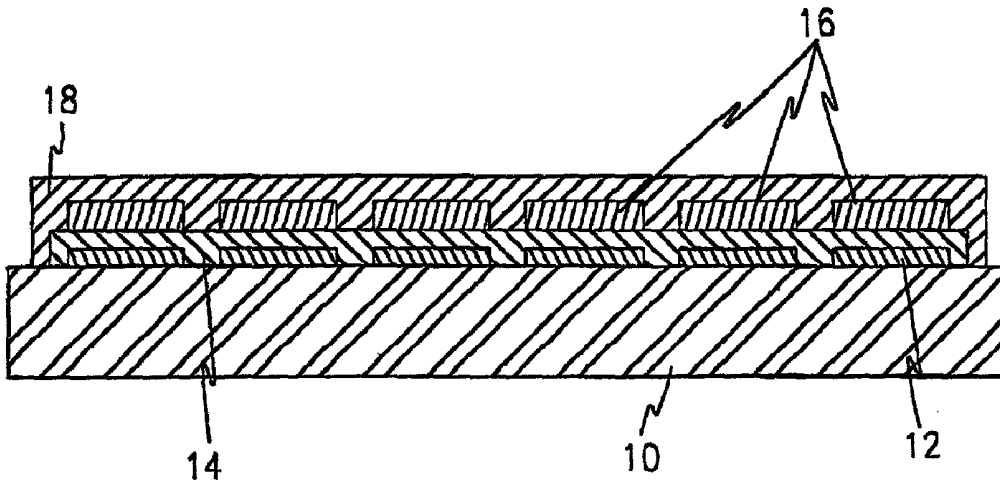

FIG. 4

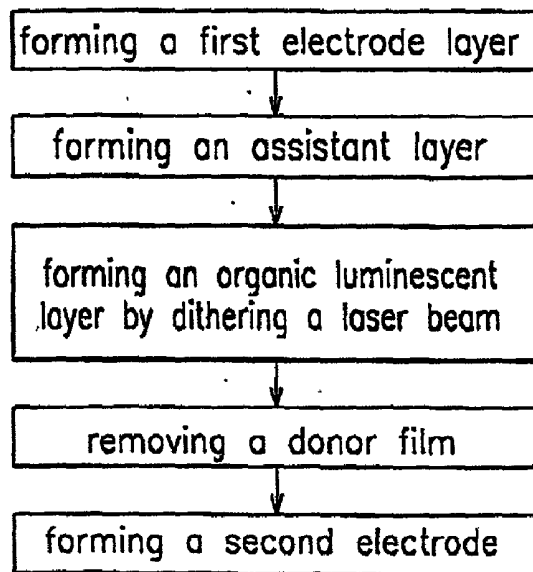

FIG. 5

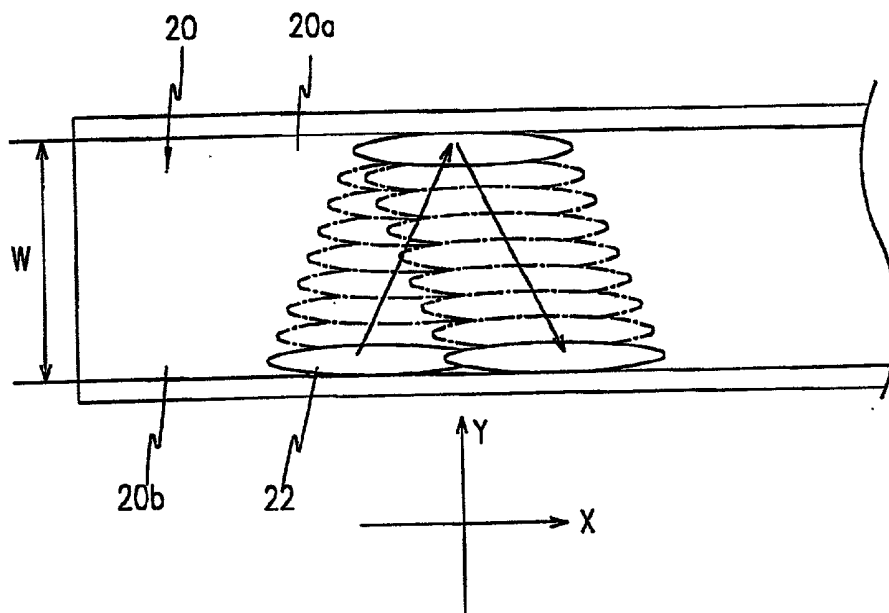

FIG. 6

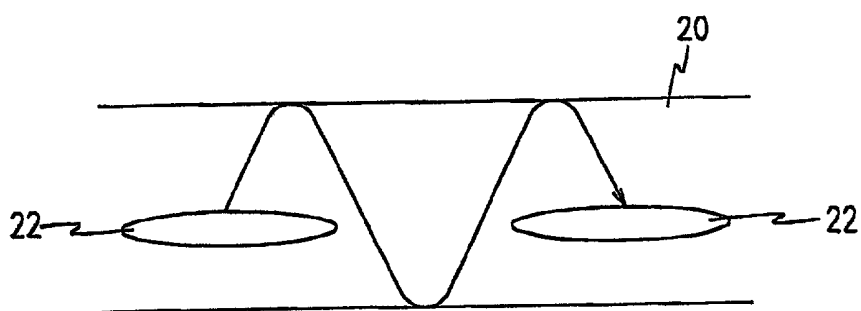

FIG. 7

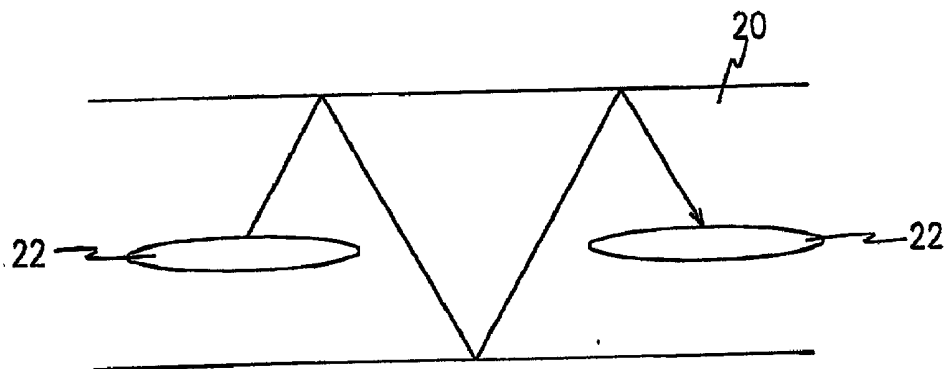

FIG. 8

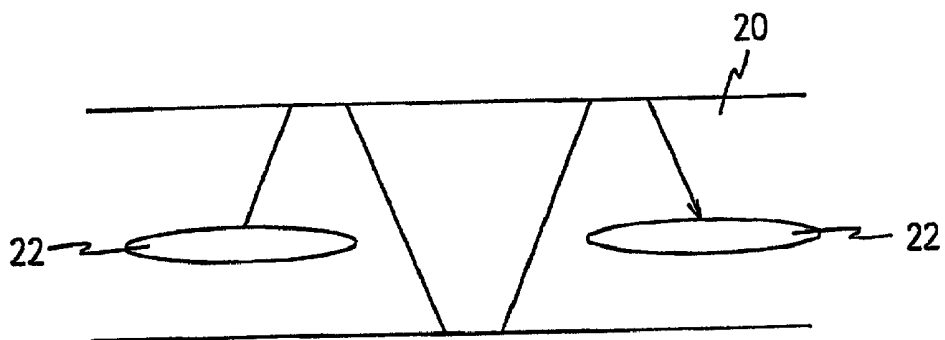

FIG. 9

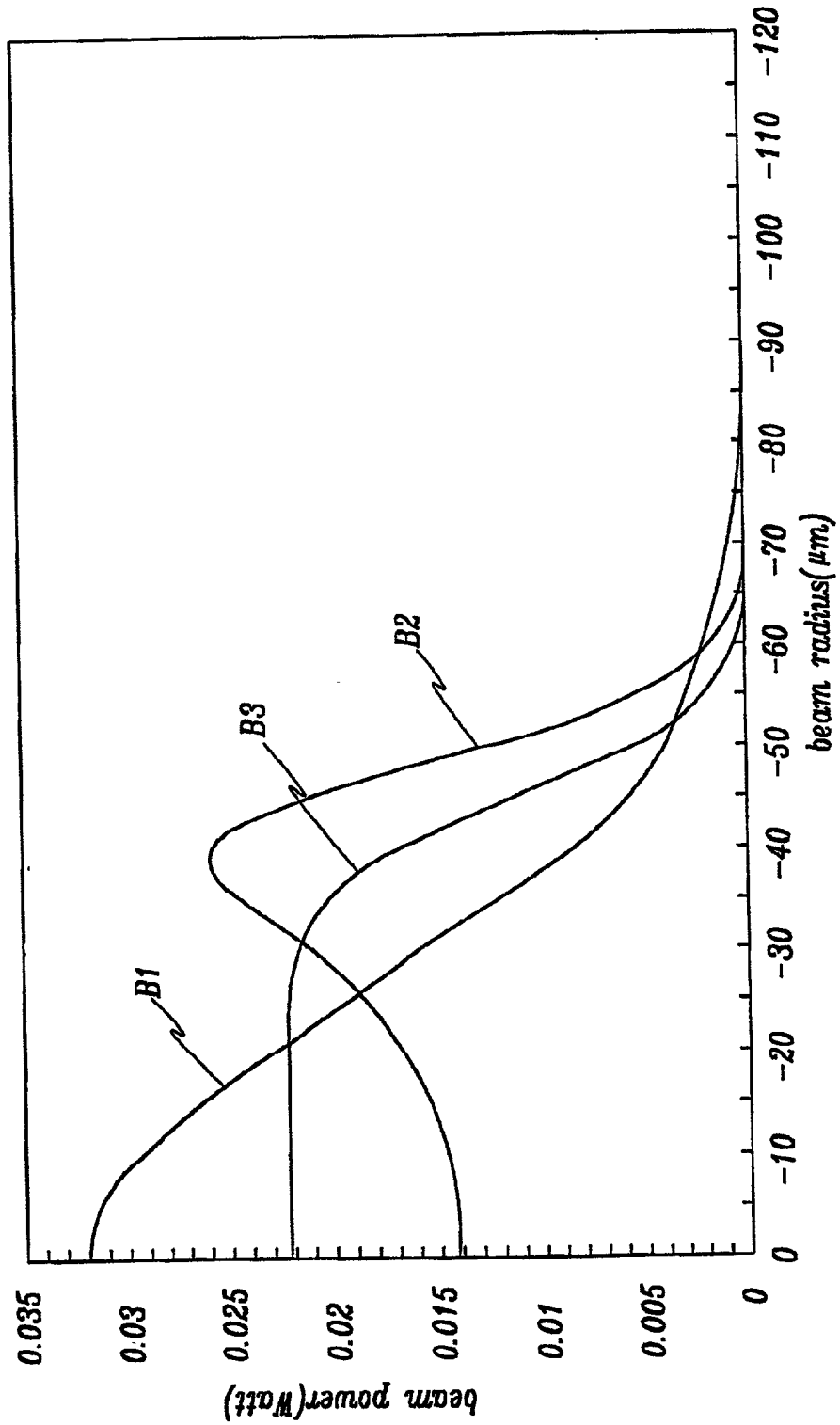

FIG.10

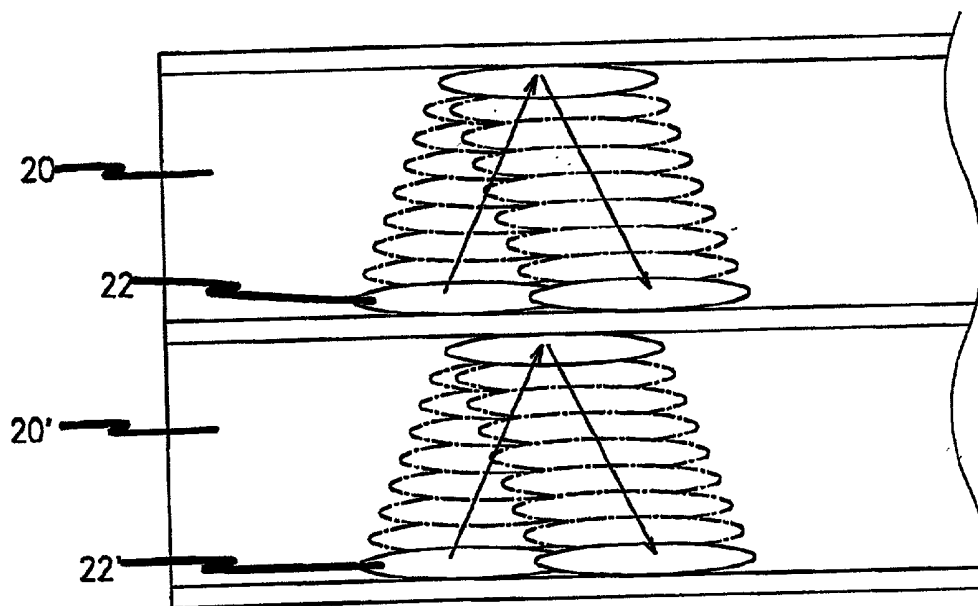

FIG.11

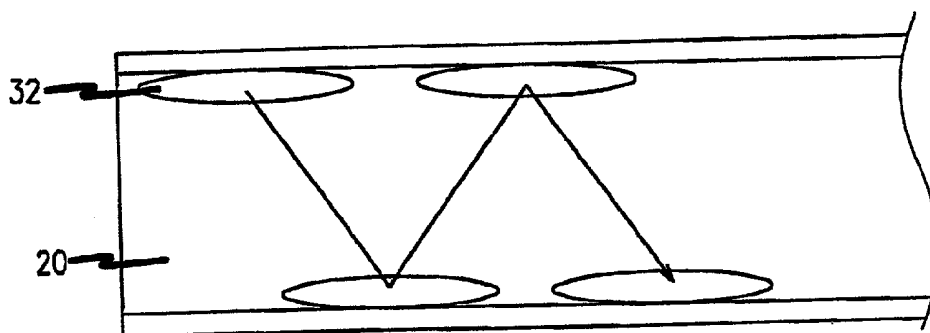

FIG.12

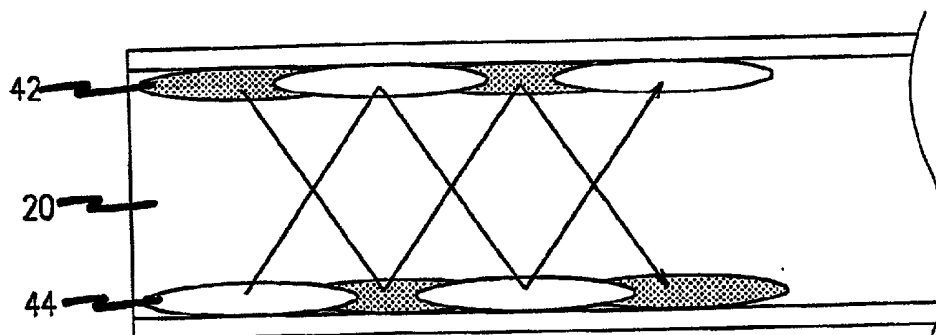

FIG. 13

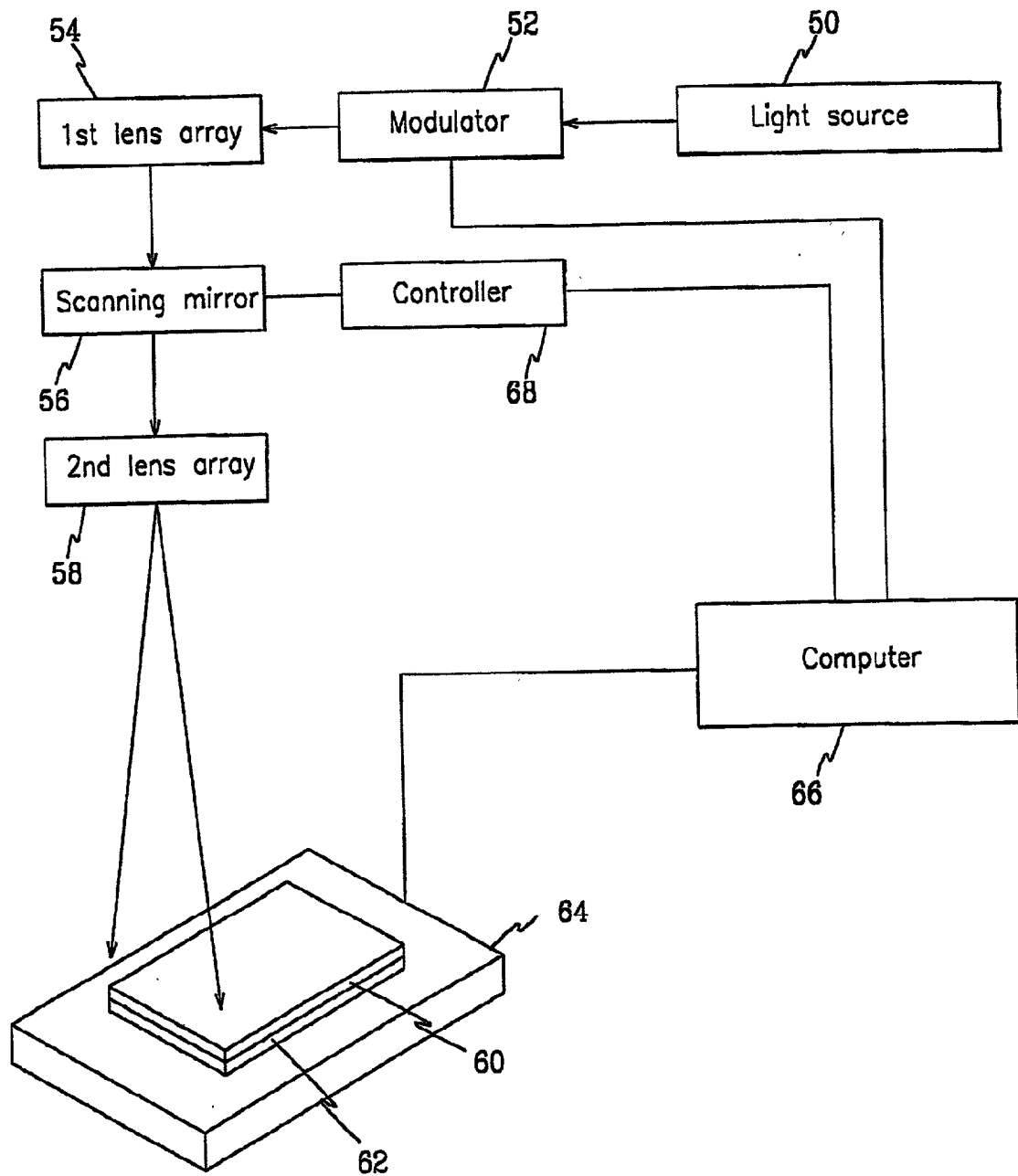

FIG.14

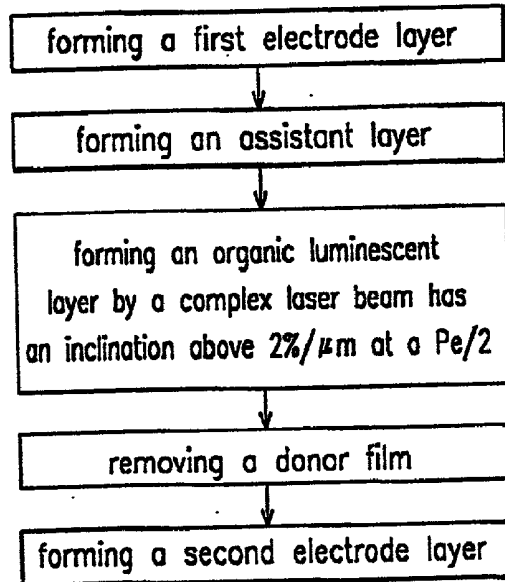
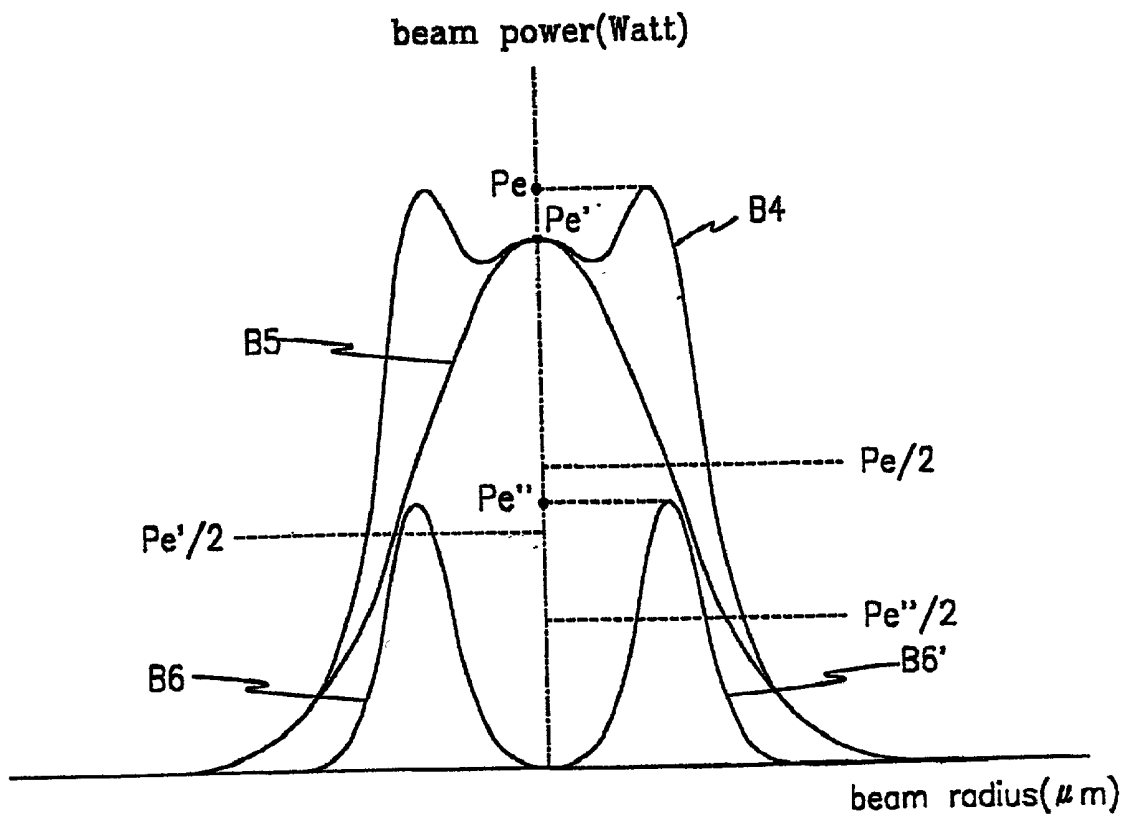

FIG.15



METHOD FOR FABRICATING ORGANIC ELECTROLUMINESCENT DISPLAY

CROSSREFERENCE TO RELATED APPLICATION

[0001] This application is based on application No. 2000-49287 filed with the Korea Patent Office on Aug. 24, 2000, the content of which is incorporated herein by reference.

BACKGROUND OF THE INVENTION

[0002] 1. Field of the Invention

[0003] The present invention relates to a method for fabricating an organic electroluminescent display that can improve the definition of an image at the edges of a pattern.

[0004] 2. Description of the Related Art

[0005] An electroluminescent display is designed to realize an image by exciting an electroluminescent material disposed between electrodes by applying a voltage to the electrodes. Such an electroluminescent display is classified into an inorganic electroluminescent display and an organic electroluminescent display according to the electroluminescent material. The former is widely used for a backlight of a watch, while the latter is developed as a display as it advantages in that it can be driven with a low voltage and has a high responsiveness and polychrome.

[0006] Generally, such an organic electroluminescent display comprises a transparent substrate, an anode electrode formed on the substrate, an organic luminescent layer covering the anode electrode, and a cathode electrode formed on the organic luminescent layer.

[0007] The organic luminescent layer may have a variety of structures according to an electroluminescent material. For example, the organic luminescent layer may be formed of a hole transport layer, an luminescent layer, and an electron transport layer.

[0008] In the above described organic electroluminescent display, the organic luminescent layer is designed to realize red (R), green (G), and blue (B) colors so that it can be applied to a color display.

[0009] Such an organic luminescent layer is generally formed through a well-known vacuum evaporative deposition process or optical etching process. However, the vacuum evaporative deposition process has a limitation in reducing the physical gap between the patterns and it is difficult to form a minute pattern to tens of μm level which is required against the possible deformation of the mask. When the optical etching process is applied, although it is possible to form the minute pattern, the property of the luminescent material forming the organic luminescent layer may be deteriorated by the developing solution or the etching solution.

[0010] Therefore, in recent years, a thermal transferring method that is a kind of dry etching processes has been proposed to form the organic luminescent layer.

[0011] The thermal transferring method converts light emitted from a light source into thermal energy by which an image formation material is transferred to a substrate to form

the organic luminescent layer. Therefore, to perform the thermal transferring method, a light source, a donor film and a substrate are required.

[0012] Describing the thermal transferring method more in detail, when light is emitted from a light source such as a laser unit to a donor film, the light is converted into thermal energy by a light absorption material of the donor film. The thermal energy allows the luminescent material of the donor film to be transferred to the surface of the substrate to form the organic luminescent layer.

[0013] That is, the organic luminescent layer is formed by scan laser beam to the donor film disposed on the substrate. The focus of the laser beam is adjusted to a predetermined value, on the donor film disposed the substrate.

[0014] U.S. Pat. No. 5,521,035 discloses a method for fabricating a color filter for a liquid crystal display through a laser thermal transferring process.

[0015] In the patent, the color filter is fabricated by a laser induction thermal transferring process for transferring a color material from a donor film to a substrate such as a glass or a polymeric film. As a laser unit, an Nd:YAG laser system may be used. This will be described with reference to **FIG. 1**.

[0016] As shown in **FIG. 1**, the Nd:YAG laser is designed to form a Gaussian beam **B1** shaped in a Gaussian functional distribution. When a diameter of the Gaussian beam **B1** is set above $60 \mu\text{m}$, the inclination of the energy distribution is reduced as it goes away from the center point **O**.

[0017] Accordingly, as shown in **FIG. 2**, when the organic luminescent layer is formed by the scanning operation of the Gaussian beam **B1** having a predetermined diameter in an X-direction, since the beam intensity is low at the both edges **20** of the organic luminescent layer, the image quality at the both edges **20** is deteriorated when compared with the central portion.

[0018] When the energy of the laser beam is intensified to improve the image quality at the edges **20**, since the energy is excessively increased at the central portion, the surface of the image pattern becomes irregular.

[0019] When the laser thermal transferring method is used to form the color filter, a transfer material (color material) is formed of a binder polymer and pigment inducing color change and dispersed in the binder polymer (acrylic acid resin or epoxy resin) at a ratio of 20-40%. The binder polymer simply functions for transmitting light. Therefore, to form a desire color pattern, a kind of binder polymer, a Tg (Glass Transition Temperature) value or a molecular weight of the binder polymer should be properly modified.

[0020] Conventionally, the color material has a Tg value of about $60-120^\circ \text{C}$. and a molecular weight of about 1,500-5,000. The color layer formed by the color material has a thickness of about $1-2 \mu\text{m}$.

[0021] When the laser thermal transferring method is used to form the organic electroluminescent display, the property (purity, Tg value, molecular weight and the like) of the transfer material (luminescent material) highly affects on the quality of the device. Therefore, when an inappropriate material is added, the quality of the device may suffer deathblow. Therefore, it is preferable to adjust the pattern

quality by adjusting the laser transferring condition rather than modifying the property of the luminescent material.

[0022] Since the luminescent material used for the organic electroluminescent display has a molecular weight above 10,000 and a T_g value above 100° C., it is relatively difficult to perform the process for forming the organic luminescent layer when compared with the process for forming the color layer. The thickness of the organic luminescent layer which should be realized through the laser thermal transferring method should be 50-100 nm which is less than that of the color layer of the color filter.

[0023] Therefore, to form such a thin organic luminescent layer, scrupulous care in setting a laser beam transferring condition and an energy distribution is further required.

SUMMARY OF THE INVENTION

[0024] It is an objective of the present invention to provide a method for fabricating an organic electroluminescent display having an improved pattern quality.

[0025] To achieve the above objective, the present invention provides a method for fabricating an organic electroluminescent display, comprising the steps of forming a first electrode layer on a transparent substrate; forming an assistant layer on the first electrode layer; forming an organic luminescent layer on the assistant layer by scanning a donor film disposed on the substrate using a laser beam; removing the donor film; and forming a second electrode on the organic luminescent layer.

[0026] The step of forming an organic luminescent layer further comprises the step of allowing the laser beam to dither with respect to an advancing direction of the laser beam.

[0027] The laser beam is radiated from a single laser unit and splitted into more than two splitted laser beams, the splitted laser beams being synchronized to simultaneously scan adjacent corresponding patterns.

[0028] Alternatively, the laser beam is formed of at least two laser beams which are radiated from at least two laser units and overlapped one another, the laser beams radiated from the laser units having an identical energy distribution.

[0029] Alternatively, the laser beam is formed of at least two laser beams radiated from at least two laser units and performing the scanning operation at a different phase. The laser beams are synchronized to simultaneously scan adjacent corresponding patterns.

[0030] A dithering speed of the laser beam is higher than an advancing speed of the laser beam.

[0031] Preferably, the dithering speed of the laser beam is about 100-1000 kHz.

[0032] Preferably, the laser beam performs the dithering operation while making one of a frequency wave selected from the group consisting of a sine-wave, a sawtooth-wave, a trapezoid-wave, or a modified sine-wave.

[0033] The laser beam has a section formed in an oval-shape having a longitudinal diameter greater than a lateral diameter, the longitudinal diameter is formed in a scan direction.

[0034] Preferably, the longitudinal diameter is about 200-500 μm and the lateral diameter is about 15-50 μm .

[0035] Preferably, wherein the organic luminescent layer is formed of a poly phenylene vinylene (PPV)-based material or poly fluorine (PF)-based material.

[0036] According to another aspect, the laser beam is a complex laser beam formed by mixing a first laser beam having a smooth inclination at a Pe'(peak of energy of the first laser beam)/2 and second laser beams having a steep inclination at a Pe"(peak of energy of the second laser beams)/2.

[0037] Preferably, the complex laser beam has an inclination above 2%/ μm at a Pe(peak of energy of the complex laser beam)/2.

[0038] Preferably, a section of the complex laser beam is formed in oval-shape.

[0039] Preferably, the complex laser beam has power of about 8 W(Watt) and an advancing speed of about 5-11 m/sec.

BRIEF DESCRIPTION OF THE DRAWINGS

[0040] The accompanying drawings, which are incorporated in and constitute a part of the specification, illustrate an embodiment of the invention, and, together with the description, serve to explain the principles of the invention:

[0041] FIG. 1 is a graph for illustrating an energy distribution of a laser beam used for a conventional thermal transferring method;

[0042] FIG. 2 is a schematic view for illustrating a method for forming a pattern using a conventional thermal transferring method;

[0043] FIG. 3 is a schematic view for illustrating an organic electroluminescent display fabricated under the present invention;

[0044] FIG. 4 is a block diagram for illustrating a method for fabricating an organic electroluminescent display according to a first embodiment of the present invention;

[0045] FIG. 5 is a schematic view for illustrating a laser thermal transferring method described with reference to FIG. 4;

[0046] FIGS. 6 to 8 are schematic views for illustrating dithering examples of a laser beam depicted in FIG. 5;

[0047] FIG. 9 is a graph for illustrating a sectional energy distribution of a laser beam used for a thermal transferring method that can be employed to the first embodiment of the present invention;

[0048] FIG. 10 is a schematic view for illustrating a first modified example of a laser thermal transferring method that can be employed to the first embodiment of the present invention;

[0049] FIG. 11 is a schematic view for illustrating a second modified example of a thermal transferring method that can be employed to the first embodiment of the present invention;

[0050] FIG. 12 is a schematic view for illustrating a third modified example of a laser thermal transferring method that can be employed to the first embodiment of the present invention;

[0051] FIG. 13 is a schematic view for illustrating a transferring apparatus for realizing the first embodiment of the present invention;

[0052] FIG. 14 is a block diagram for illustrating a method for fabricating an organic electroluminescent display according to a second embodiment of the present invention; and

[0053] FIG. 15 is a graph for illustrating a sectional energy distribution of a laser beam applied to the second embodiment.

DETAILED DESCRIPTION OF THE PREFERRED EMBODIMENTS

[0054] Preferred embodiments of the present invention will be described in detail with reference to the accompanying drawings.

[0055] FIG. 3 shows an organic electroluminescent display fabricated under the present invention, and FIG. 4 shows a method for fabricating an organic electroluminescent display according to a first embodiment of the present invention.

[0056] As shown in the drawings, a first electrode layer 12 having a thickness of about 100-500 nm is formed on a transparent substrate 10 by sputtering ITO (Indium Tin Oxide).

[0057] An assistant layer (hole transport layer) 14 having a thickness of about 10-100 nm is formed on the first electrode layer 12 by, for example, a spin coating process, a dip coating process, a vacuum evaporative deposition process, or a thermal transferring process. An R. G. B organic luminescent layer 16 is formed on the assistant layer (hole transport layer) 14 by a thermal transferring process according to a feature of the present invention. A second electrode layer 18 intersecting the first electrode layer at right angles is formed on the organic luminescent layer 16.

[0058] Preferably, the second electrode layer 18 is formed by depositing aluminum through a vacuum evaporative deposition process at a thickness of about 50-1500nm. An insulating layer formed of an organic material such as polymer photoresist or an inorganic material such as SiO₂ and SiN₂ may be deposited between the line patterns of the first electrode.

[0059] In addition, a material such as LiF, Ca, or Ba may be disposed between the organic luminescent layer and the second electrode layer.

[0060] Preferably, the organic luminescent layer 16 is formed of a poly phenylene vinylene (PPV)-based material or poly fluorine (PF)-based material.

[0061] FIG. 5 shows a schematic view for illustrating a laser thermal transferring method described with reference to FIG. 4.

[0062] In the drawing, the reference numeral 22 indicates a laser beam for scanning a pattern 20.

[0063] The laser beam 22 moves from left to right in the drawing (i.e., in an X-direction) along the pattern 20 to perform the scanning process. At this point, while moving in the X-direction, the laser beam 22 dithers in a Y-direction.

[0064] By the dithering movement of the laser beam 22, the thermal transferring process is effectively realized even at both edges 20a and 20b of the pattern 20. The dithering movement is realized by alternating the advancing direction of the laser beam under the control of an acousto-optic modulator (AOM).

[0065] In addition, the dithering speed (i.e., a moving speed in the Y-direction) is preferably higher than the advancing speed (i.e., an advancing speed in the X-direction). That is, considering the advancing speed and the energy distribution, it is preferable to set the dithering speed at about 100-10,000 KHz.

[0066] Although the section of the laser beam may be formed in a circular-shape, but it is more preferable to be formed in an oval-shape. Particularly, as shown in the drawing, the section of the oval-shaped laser beam 22 is designed such that a diameter in a direction of an X-axis (in the advancing direction) is greater than a diameter in a direction of a Y-axis (in the dithering direction). Therefore, when the scanning is performed, the overlap ratio of the laser beams is increased, whereby the energy distribution is uniformly applied to the entire portion of the pattern 20.

[0067] When the lateral width W of the pattern 20 is 60-150 μ m, it is preferable that the section of the laser beam is oval-shaped having the X-axis diameter of 200-500 μ m and the Y-axis diameter of 15-50 μ m.

[0068] As shown in FIGS. 6 to 8, the laser beam performs its scanning operation while making a sine-wave (see FIG. 6), a sawtooth-wave (see FIG. 7), a trapezoid-wave (see FIG. 8), or a modified sine-wave (not shown). At this point, the sectional energy distribution of the laser beam 22 is as shown in FIG. 9.

[0069] As shown in FIG. 9, when the laser beam performs its scanning operation without the dithering movement, the laser beam (i.e., Gaussian beam B1) has an energy distribution having an inclination reduced as it goes from the central portion to the edges of the pattern.

[0070] However, the laser beam 22 of the present invention has an energy distribution having an inclination steeply increased as it goes from the central portion to the edges of the pattern (See graphs B2 and B3 in FIG. 9 which respectively represent the laser beams performing their dithering movements in the shape of the sine-wave and the trapezoid-wave).

[0071] As described above, the intensity of the laser beam 22 of the present invention is not reduced even at the edges 20a and 20b of the pattern 20, thereby effectively realizing the thermal transferring process. That is, as in the conventional laser beam B1, when the beam intensity is increased to compensate for the intensity of the beam edge, the surface of the pattern becomes uneven. However, the laser beam of the present invention has the beam intensity throughout its entire area, there is no need to increase the beam intensity to compensate for the beam edge. As a result, the flatness of the pattern can be improved.

[0072] In the above-described first embodiment, a single laser beam is radiated from a single laser unit. However, the present invention is not limited to this.

[0073] That is, as shown in FIG. 10, plural split laser beams 22 and 22' may be radiated from a single laser unit (not shown) so that plural organic luminescent layer patterns 20 and 20' are simultaneously scanned. Preferably, the plural split laser beams are synchronized. This allows the process time to be saved,

[0074] Alternatively, as shown in FIG. 11, plural laser beams radiated from plural laser units are overlapped one another to form a single overlapped laser beam 32. As more than two laser beams are overlapped, the beam intensity is increased, reducing the scanning time.

[0075] Alternatively, as shown in FIG. 12, plural laser beams 42 and 44 are radiated from plural laser units (not shown) and perform the scanning operation with different phases.

[0076] FIG. 13 shows a thermal transferring apparatus for realizing the above-described thermal transferring methods.

[0077] A light source 50 radiates a solid laser beam such as ND/YAG or a gas laser beam such as CO₂ laser.

[0078] As described above, the radiated laser beam may be the single laser beam or the split laser beams or the single overlapped laser beam. The split laser beams may be advanced in an overlapped state or in different phases.

[0079] The laser beam (i.e., the single laser beam or the split laser beams or the single overlapped laser beam) radiated from the light source 50 is adjusted in its intensity by a modulator 52 and then reach a scanning mirror 56 via a first lens array 54.

[0080] The scanning mirror 56 guides the laser beam path to the target on the substrate.

[0081] The laser beam reached the scanning mirror 56 is emitted to the donor film 60, on which a luminescent material is deposited, via a second lens array 58. Then, only a portion of the donor film 60, which is scanned by the laser beam, is transferred to the substrate 62.

[0082] The donor film 60 and the substrate 62 are supported on a stage 64 whose movement is controlled by a computer 66. The computer 66 also controls the scanning mirror 56 through a scanning mirror controller 68.

[0083] The dithering movement of the laser beam is controlled by the modulator 52 which is controlled by the computer 66.

[0084] In the above modified examples, the laser beams are dithered various type. However, the present invention is not limited to this. As shown in FIGS. 14 and 15, plural laser beams having a different energy distribution from each other may be mixed. That is, a complex laser beam B4 may be formed by mixing a laser beam B5 having a smooth inclination at the Pe'(peak of energy of the laser beam B5)/2 and laser beams B6 and B6' having a steep inclination at the Pe''(peak of energy of the laser beams B6 AND B6')/2.

[0085] As the laser beam B5, laser beam having an inclination of about 1.0-6.0%/μm at the Pe'/2 and a lateral diameter of about 40-200 μm is preferably used, and as the

laser beams B6 and B6', laser having an inclination of about 3~8%/μm at the Pe''/2 and a lateral diameter of about 30~75 μm is preferably used.

[0086] Accordingly, the complex laser beam B4 has an inclination of the energy distribution above 2.0%/μm at the Pe/2. This shows that the inclination of the complex laser beam is greater than that of the Gaussian beam (B1 in FIG. 1).

[0087] The Gaussian beam has an inclination of about 1.4%/μm at the peak of energy/2.

[0088] The complex laser beam 54 has a section formed in an oval-shape having a longitudinal diameter greater than a lateral diameter, the longitudinal diameter is formed in a scan direction, and power of about 8 W(Watt) and an advancing speed of about 5~11 m/sec.

[0089] As describe above, the laser beam (i.e., Gaussian beam B1) has an energy distribution having a smooth inclination as it goes from the central portion to the edges of the pattern, while the complex laser beam B4 of the present invention has an energy distribution having a steep inclination as it goes from the central portion to the edges of the pattern. That is, the intensity of the complex laser beam B4 is not reduced even at the edges 20a and 20b of the pattern 20, thereby effectively realizing the thermal transferring process. That is, as in the conventional laser beam B1, when the beam intensity is increased to compensate for the intensity of the beam edge, the surface of the pattern becomes uneven. However, the complex laser beam B4 of the present invention has the beam intensity through out its entire area, there is no need to increase the beam intensity to compensate for the beam edge. As a result, the flatness of the pattern can be improved.

[0090] While this invention has been described in connection with what is presently considered to be the most practical and preferred embodiments, it is to be understood that the invention is not limited to the disclosed embodiments, but, on the contrary, is intended to cover various modifications and equivalent arrangements included within the spirit and scope of the appended claims.

What is claimed is:

1. A method for fabricating an organic electroluminescent display, comprising the steps of:

forming a first electrode layer on a transparent substrate;

forming an organic luminescent layer on the assistant layer by scanning a donor film disposed on the substrate using a laser beam;

removing the donor film; and

forming a second electrode layer on the organic luminescent layer.

2. A method of claim 1 wherein the step of forming an organic luminescent layer further comprises the step of allowing the laser beam to dither with respect to an advancing direction of the laser beam.

3. A method of claim 2 wherein the laser beam is radiated from a single laser unit.

4. A method of claim 2 wherein the laser beam is radiated from a single laser unit and splitted into more than two

splitted laser beams, the splitted laser beams being synchronized to simultaneously dither adjacent corresponding patterns.

5. A method of claim 2 wherein the laser beam is formed of at least two laser beams which are radiated from at least two laser units and overlapped one another, the laser beams radiated from the laser units having an identical energy distribution.

6. A method of claim 2 wherein the laser beam is formed of at least two laser beams radiated from at least two laser units and performing the scanning operation at a different phase.

7. A method of claim 2 wherein the laser beam is formed of at least two laser beams radiated from at least two laser units and the laser beams being synchronized to simultaneously scan adjacent corresponding patterns.

8. A method of claim 2 wherein a dithering speed of the laser beam is higher than an advancing speed of the laser beam.

9. A method of claim 8 wherein the dithering speed of the laser beam is about 100-1000 kHz.

10. A method of claim 2 wherein the laser beam performs the scanning operation while making one of a frequency wave selected from the group consisting of a sine-wave, a sawtooth-wave, a trapezoid-wave or a modified sine-wave.

11. A method of claim 2 wherein the laser beam has a section formed in an oval-shape having a longitudinal diameter greater than a lateral diameter, the longitudinal diameter is formed in a scan direction.

12. A method of claim 11 wherein the longitudinal diameter is about 200-500 μm and the lateral diameter is about 15-50 μm .

13. A method of claim 13 wherein the organic luminescent layer is formed of a poly phenylene vinylene (PPV)-based material or poly fluorine (PF)-based material.

14. A method of claim 1 wherein the laser beam is a complex laser beam formed by mixing a first laser beam having a smooth inclination at the $\text{Pe}^{\prime}/2$ and second laser beams having a steep inclination at the $\text{Pe}^{\prime}/2$.

15. A method of claim 14 wherein the complex laser beam has an inclination above 2.0%/ μm at the $\text{Pe}^{\prime}/2$.

16. A method of claim 14 wherein the complex laser beam has a section formed in an oval-shape having a longitudinal diameter greater than a lateral diameter, the longitudinal diameter is formed in a scan direction.

17. A method of claim 16 wherein the second laser beams having an inclination of about 3.0-8.0%/ μm at the $\text{Pe}^{\prime}/2$ and a lateral diameter of about 30-75 μm .

18. A method of claim 16 wherein the first laser beam has an inclination of about 1.0-6.0%/ μm at the $\text{Pe}^{\prime}/2$ and a lateral diameter of about 40-200 μm .

19. A method of claim 1 further comprising the steps of forming assistant layer on the first electrode layer.

* * * * *

专利名称(译)	制造有机电致发光显示器的方法		
公开(公告)号	US20020028626A1	公开(公告)日	2002-03-07
申请号	US09/935332	申请日	2001-08-23
[标]申请(专利权)人(译)	李圣TAEK KWON张赫 KANG TAE MIN PARK JOON YOUNG		
申请(专利权)人(译)	李圣泽 KWON张赫 KANG TAE MIN PARK JOON YOUNG		
当前申请(专利权)人(译)	李圣泽 KWON张赫 KANG TAE MIN PARK JOON YOUNG		
[标]发明人	LEE SEONG TAEK KWON JANG HYUK KANG TAE MIN PARK JOON YOUNG		
发明人	LEE, SEONG-TAEK KWON, JANG HYUK KANG, TAE MIN PARK, JOON YOUNG		
IPC分类号	H05B33/10 H01L51/00 H01L51/40 H01J9/00		
CPC分类号	H01L51/0009		
优先权	1020000049287 2000-08-24 KR		
其他公开文献	US6936300		
外部链接	Espacenet USPTO		

摘要(译)

在制造有机电致发光显示器的方法中，在透明基板上形成第一电极层，并在第一电极层上形成空穴传输层。在通过使用激光束扫描设置在基板上的供体膜在空穴传输层上形成有机发光层之后，移除供体膜，然后在有机发光层上形成第二电极。激光束在执行扫描操作时抖动，以使能量分布均匀。

